

DH1~DH2=16171 (±20)

Coordinates

Mark	X	Y	R
GM	0	0	—
h1	7270	4825	350
h2	-7270	4825	350
h3	-7270	-4825	350
h4	7557	-4025	325
DH1	-7900	-3000	—
DH2	8234	-1900	—
a1	2793	7550	500
a2	6600	5539	300
a3	7200	4787	300
a4	8299	3350	300
a5	8800	1632	300
a6	8800	-1632	300
a7	8299	-3350	300
a8	7200	-4787	300
a9	6600	-5539	300
a10	2793	-7550	500
a11	-2793	-7550	500
a12	-6600	-5539	300
a13	-7200	-4787	300
a14	-8299	-3350	300
a15	-8800	-1632	300
a16	-8800	1632	300
a17	-8299	3350	300
a18	-7200	4787	300
a19	-6600	5539	300
a20	-2793	7550	500
f21	5788	7505	1500
f22	5788	-7505	1500
f23	-5788	-7505	1500
f24	-6864	6800	1500

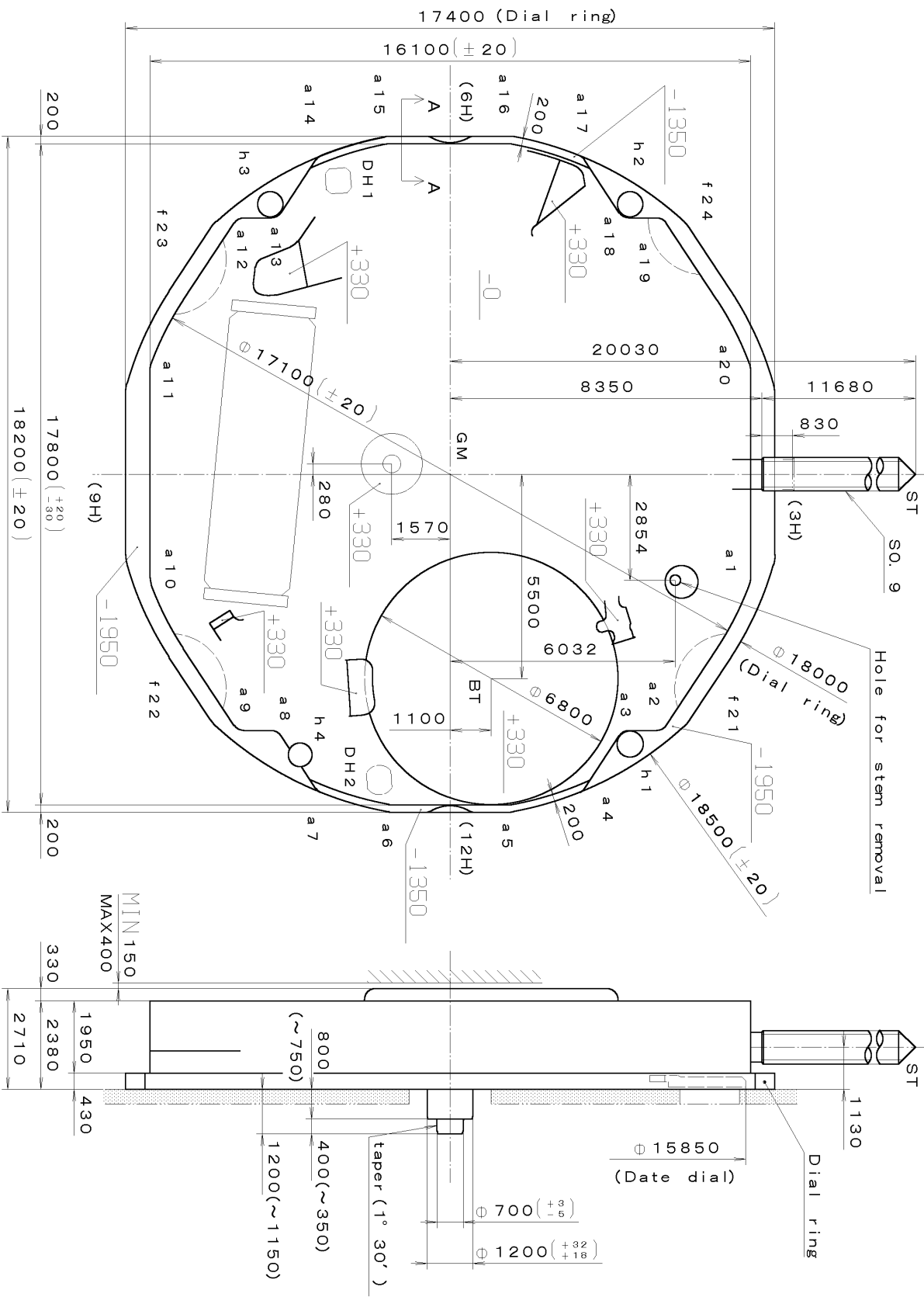

Basement metal

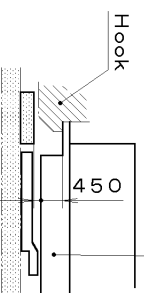

Section f21~f24

Casing Holder

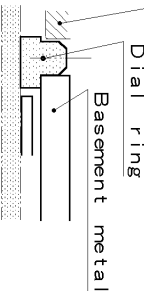

Section h1~h4

Basement metal

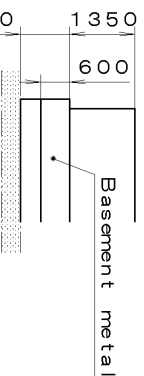

Section A-A

Material	Quantity	Unit	Cal. No. : 1L15
Heat Treatment	Scale	1/1000 mm	Parts :
Hardness	Date	9:1	
Plating	Drawn		
	Checked	T. Hiruta	Name :
	Approved		Frame for Case
			Drawing No. : 1L15C0000
General Tolerances			
Dimensions			
Angles			

CITIZEN WATCH CO., LTD.
TOKYO, JAPAN

This drawing is provisional and subject to our reconfirmation and/or revision without notice.

*** T I P W (01) *** (2100 1121) 00-06-14

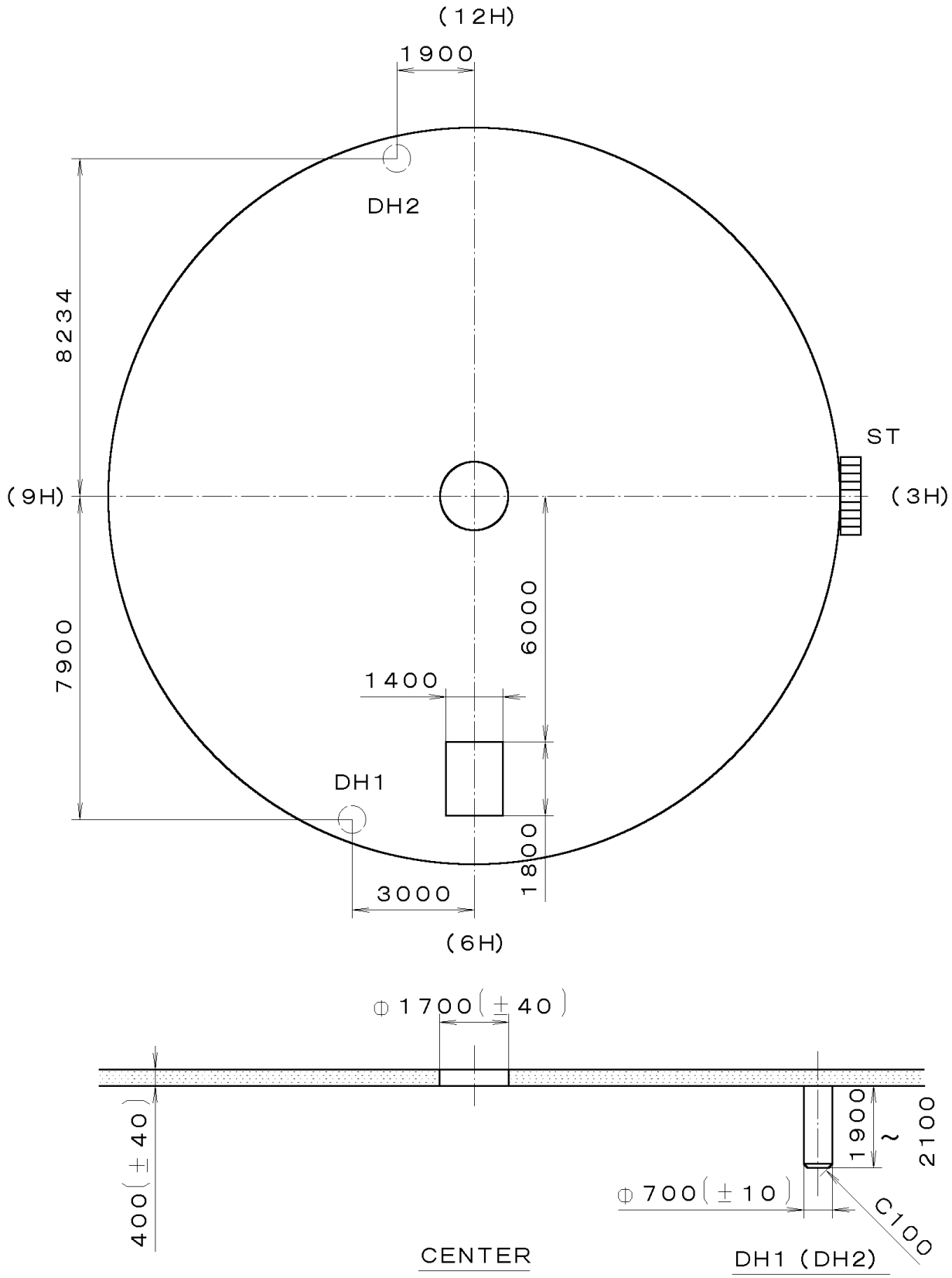

7		Quantity		Cal. No. :	1L12-10Z
6		Unit	1/1000 mm	Parts:	
5		Scale	7:1	Name:	Indications for Dial
4		Date		Drawing No. :	1L12D000
3		Drawn			
2		Checked	T. Hiruta		
1		Approved			
Material					
Heat Treatment		General Tolerances		CITIZEN WATCH CO.,LTD. TOKYO, JAPAN	
Hardness		Dimensions			
Plating		Angles			

This drawing is provisional and subject to our reconfirmation and/or revision without notice.

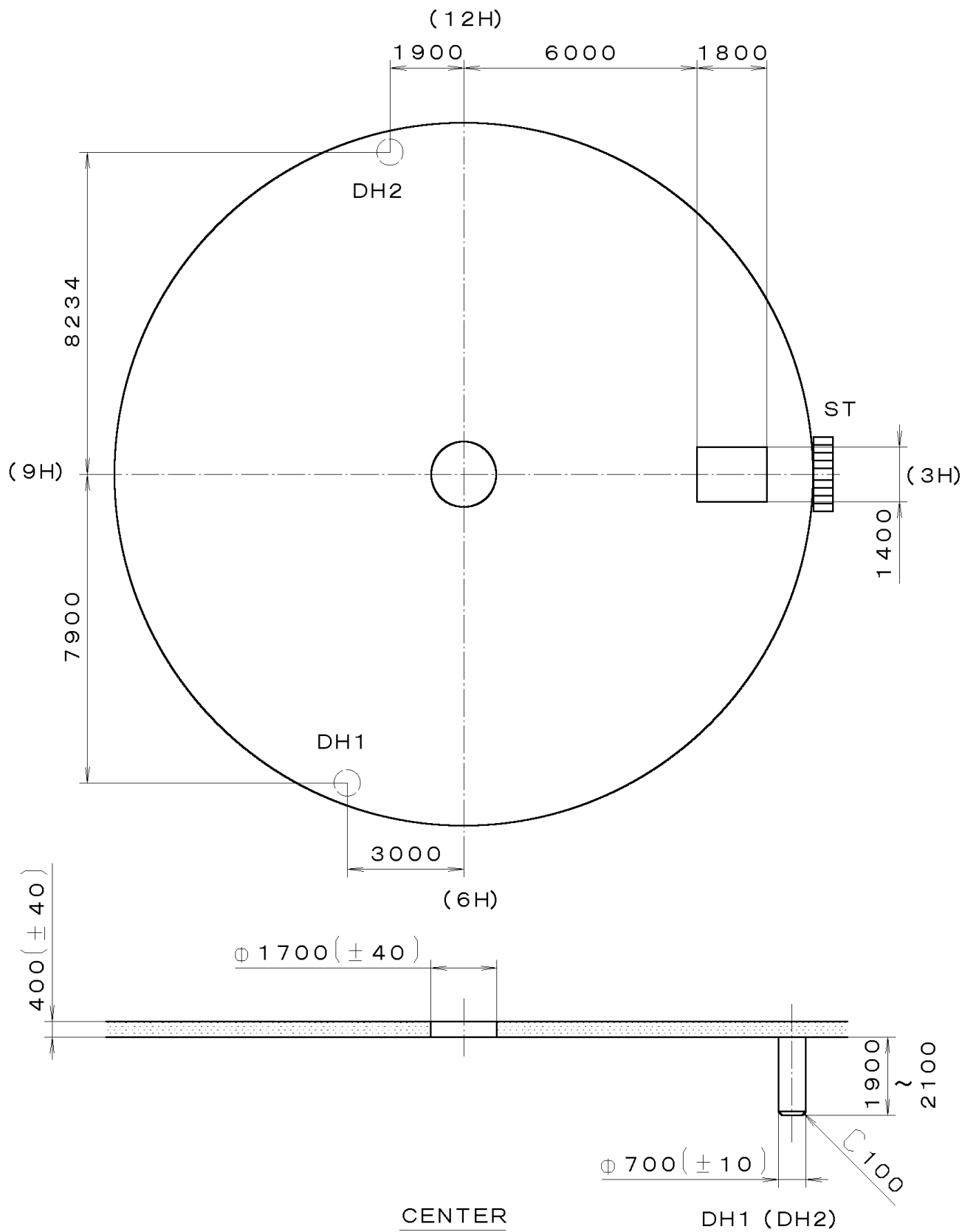

00-06-16
(2100 1121)
(01) ***
1L12-10A
*** T I P W

		Quantity		Cal. No. :	1L12-10A
		Unit	1/1000 mm	Parts:	
		Scale	7:1	Name:	Indications for Dial
		Date		Drawing No. :	1L12D010
		Drawn			
		Checked	T. Hiruta		
		Approved			
Material					
Heat Treatment		General Tolerances		CITIZEN WATCH CO., LTD. TOKYO, JAPAN	
Hardness		Dimensions			
Plating		Angles			

This drawing is provisional and subject to our reconfirmation and/or revision without notice.

065-505 (01) *** (2100 1121 A-01 A-01) 00-06-22

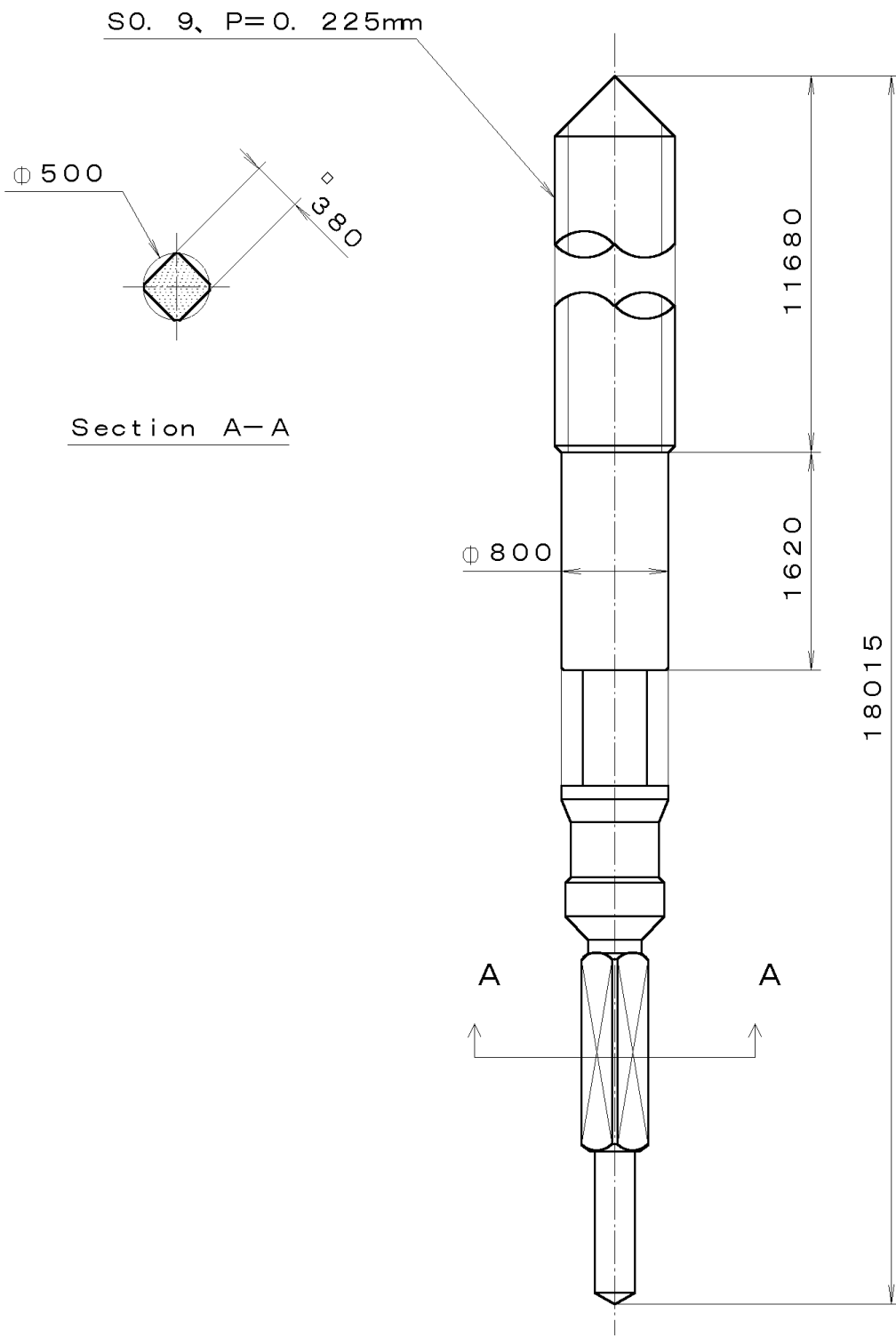

7			Quantity		Cal. No. :
6			Unit	1/1000 mm	
5			Scale	20:1	Parts:
4			Date		065-505
3			Drawn		Name:
2			Checked	T. Hiruta	SETTING STEM
1			Approved		Drawing No. : 5050S000
Material					
Heat Treatment				General Tolerances	
Hardness		Dimensions		CITIZEN WATCH CO., LTD. TOKYO, JAPAN	
Plating		Angles			