

*** T1PW 1L02 (01) *** (2100 1121) 00-06-26

DH1~DH2=16171 (±20)

Coordinates

Mark	X	Y	R
GM	0	0	—
h1	7270	4825	350
h2	-7270	4825	350
h3	-7270	-4825	350
h4	7557	-4025	325
DH1	-7900	-3000	—
DH2	8234	-1900	—
a1	2793	7550	500
a2	6600	5539	300
a3	7200	4787	300
a4	8299	3350	300
a5	8800	1632	300
a6	8800	-1632	300
a7	8299	-3350	300
a8	7200	-4787	300
a9	6600	-5539	300
a10	2793	-7550	500
a11	-2793	-7550	500
a12	-6600	-5539	300
a13	-7200	-4787	300
a14	-8299	-3350	300
a15	-8800	-1632	300
a16	-8800	1632	300
a17	-8299	3350	300
a18	-7200	4787	300
a19	-6600	5539	300
a20	-2793	7550	500
f21	5788	7505	1500
f22	5788	-7505	1500
f23	-5788	-7505	1500
f24	-6864	6800	1500

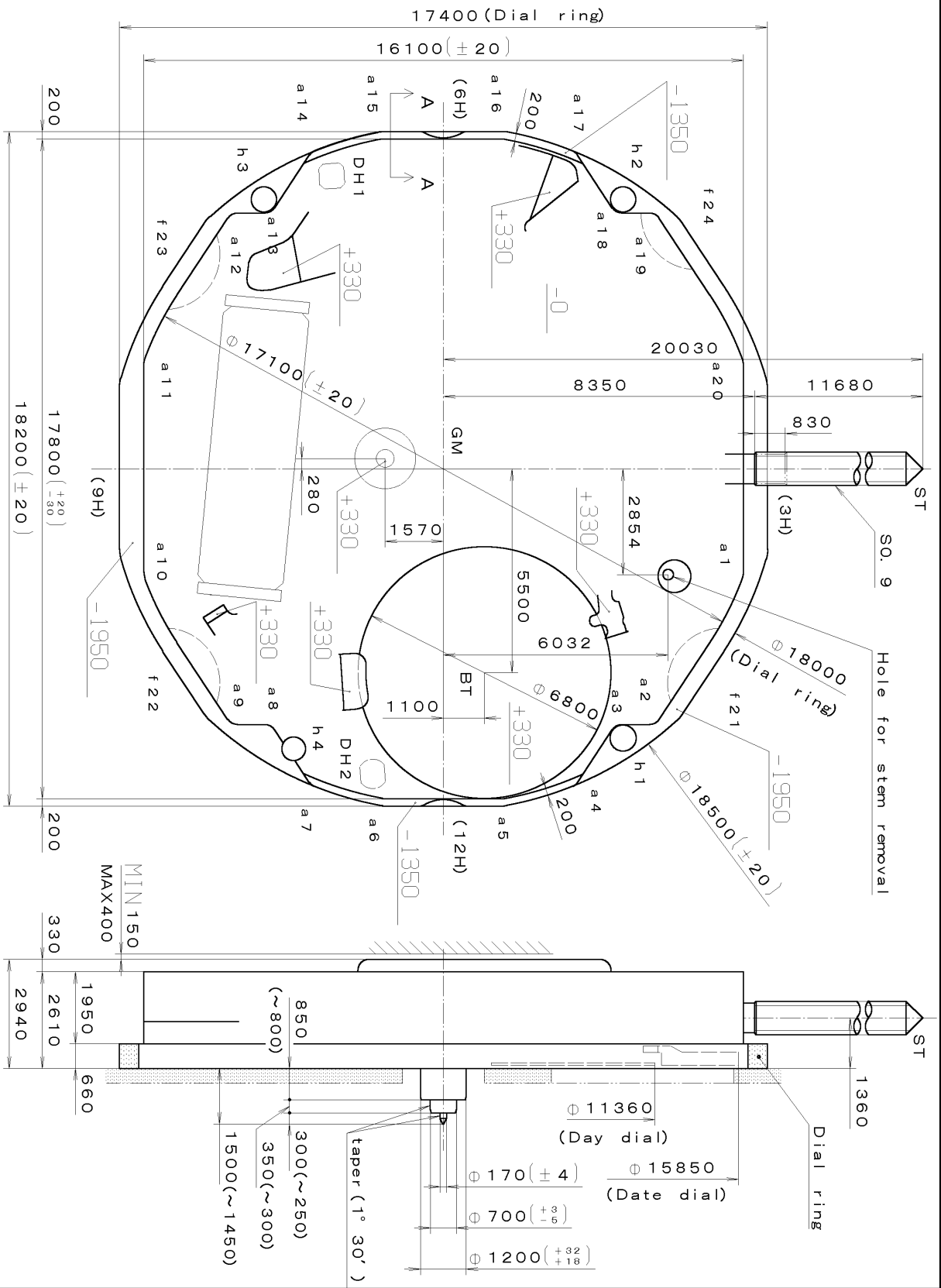

Basement metal

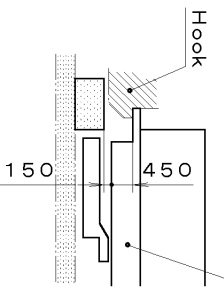

Section f21~f24

Casing Holder

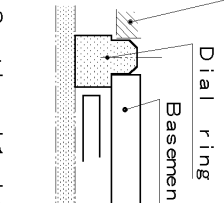

Section h1~h4

Basement metal

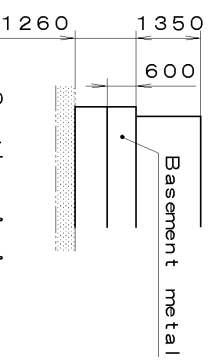

Section A-A

Material	Quantity	Cal. No. :
Heat Treatment	Unit	1L02
Hardness	Scale	9:1
Plating	Date	
	Drawn	
	Checked	T. Hiruta
	Approved	
General Tolerances		Drawing No. : 1L02C0000
Dimensions		
Angles		

CITIZEN WATCH CO., LTD.
TOKYO, JAPAN

This drawing is provisional and subject to our reconfirmation and/or revision without notice.

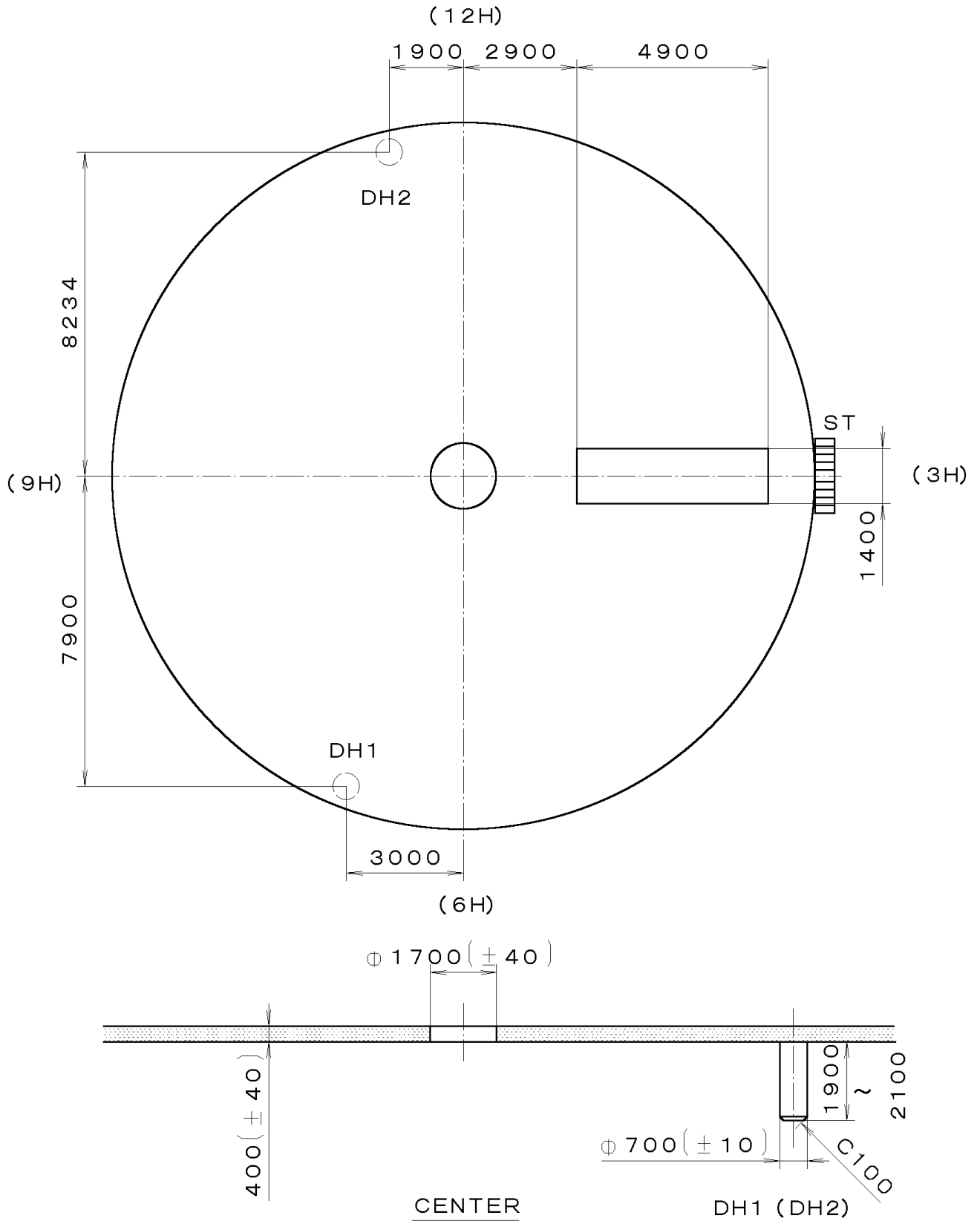

T I P W 1 L 0 2 - 1 0 A (0 1) * * * * (2 1 0 0 1 1 2 1)			Quantity		Cal. No. : 1L02-10A
			Unit	1/1000 mm	
			Scale	7:1	Parts:
			Date		
			Drawn		
			Checked	T. Hiruta	Name:
			Approved		Indications for Dial
Material				Drawing No. : 1L02D000	
Heat Treatment		General Tolerances		CITIZEN WATCH CO.,LTD. TOKYO, JAPAN	
Hardness		Dimensions			
Plating		Angles			

This drawing is provisional and subject to our reconfirmation and/or revision without notice.

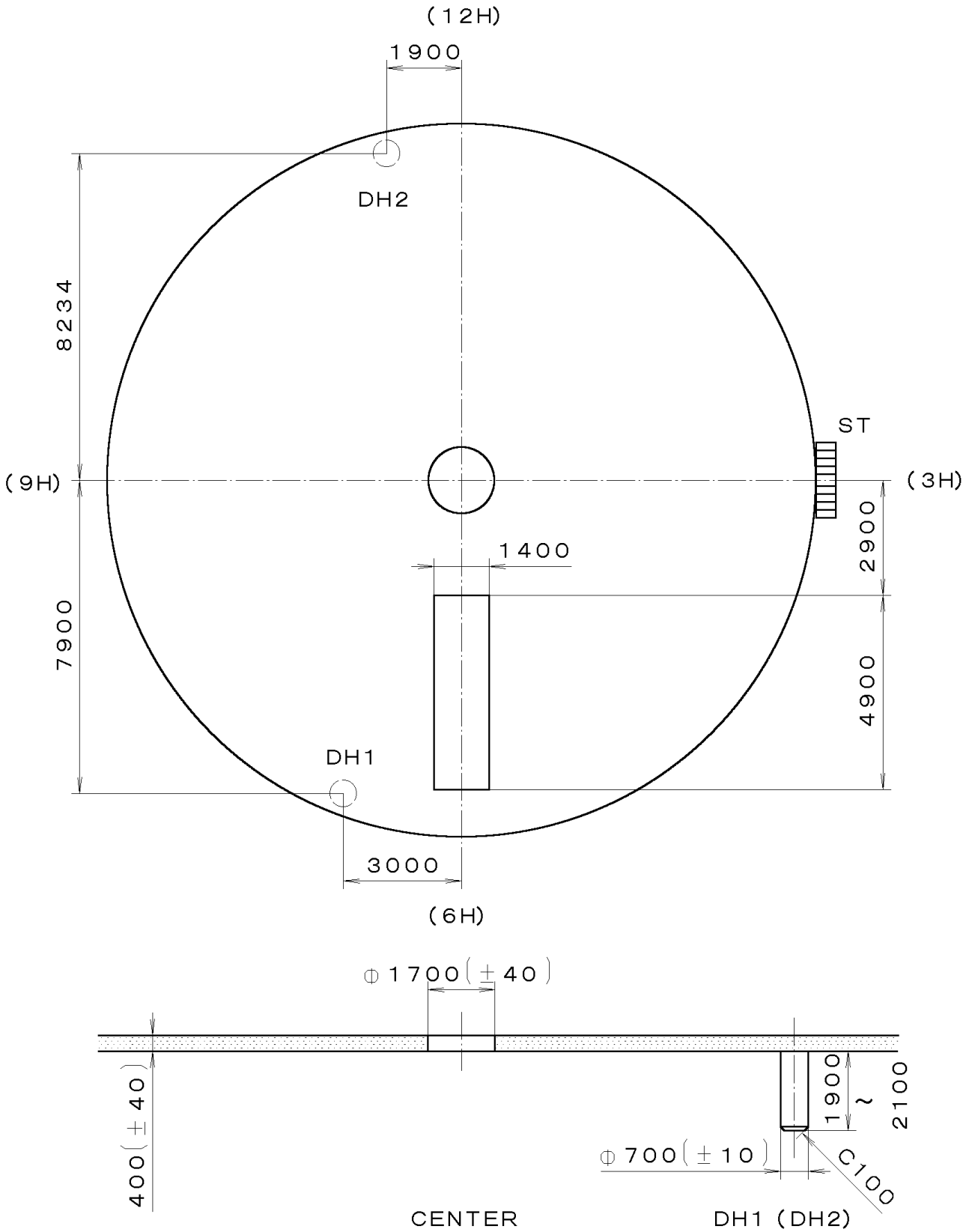

*** T I P W (01) *** (2100 1121) 1L02-1AC ***

7		Quantity		Cal. No. :	1L02-1AC
6		Unit	1/1000 mm	Parts:	
5		Scale	7:1	Name:	
4		Date		Indications for Dial	
3		Drawn		Drawing No. :	1L02D020
2		Checked	T. Hiruta		
1		Approved			
Material					
Heat Treatment		General Tolerances		CITIZEN WATCH CO.,LTD. TOKYO, JAPAN	
Hardness		Dimensions			
Plating		Angles			

This drawing is provisional and subject to our reconfirmation and/or revision without notice.

*** T I P W (01) *** (2100 1121) 1L02-1XZ

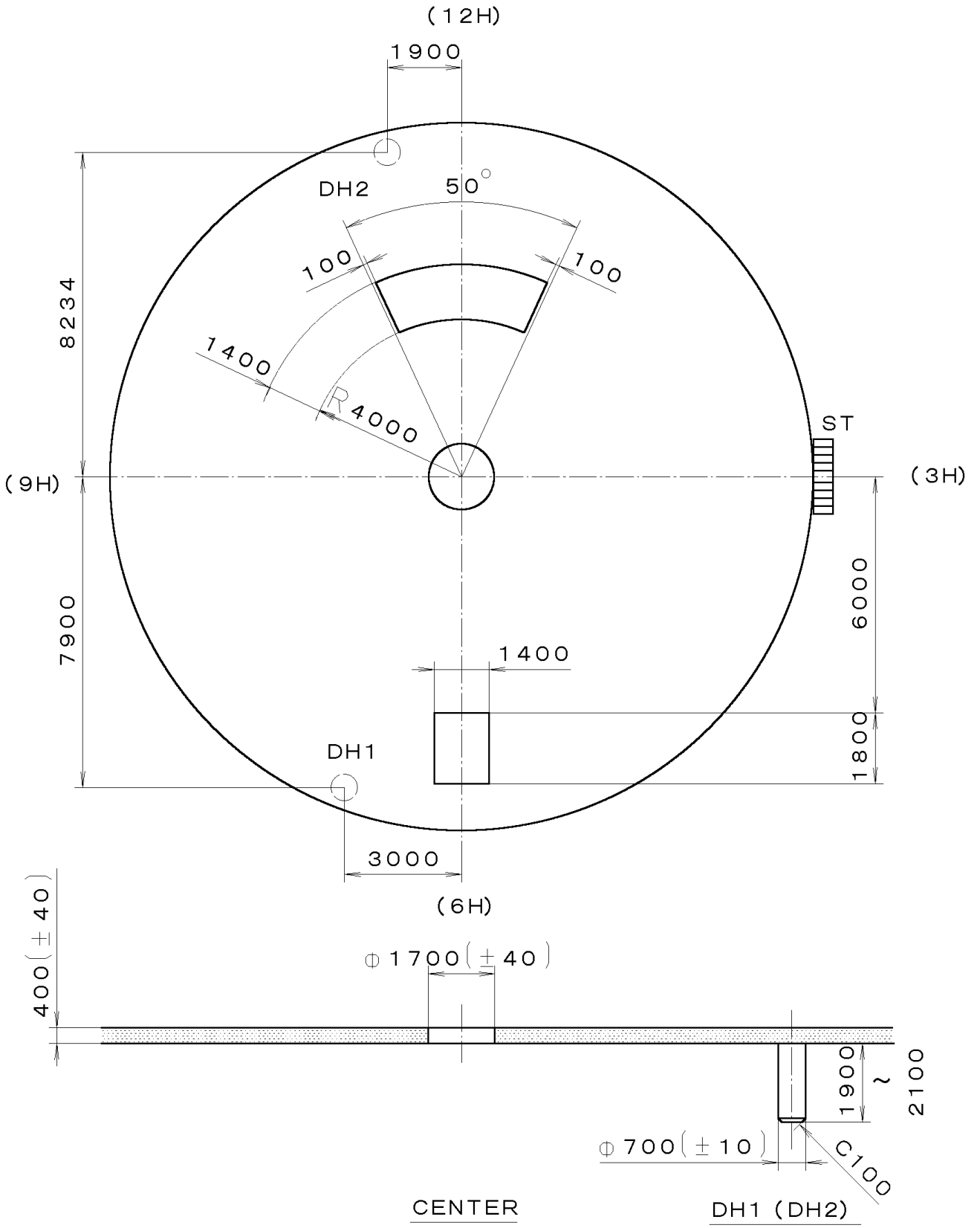

7			Quantity		Cal. No. :	1L02-1XZ
6			Unit	1/1000 mm	Parts :	
5			Scale	7:1	Name :	Indications for Dial
4			Date		Drawing No. :	1L02D030
3			Drawn			
2			Checked	T. Hiruta		
1			Approved			
Material			General Tolerances			CITIZEN WATCH CO.,LTD. TOKYO, JAPAN
Heat Treatment			Dimensions			
Hardness			Angles			
Plating						

This drawing is provisional and subject to our reconfirmation and/or revision without notice.

00-06-14
(2100 1121)
1L02-1AZ (01) ***
*** T I P W

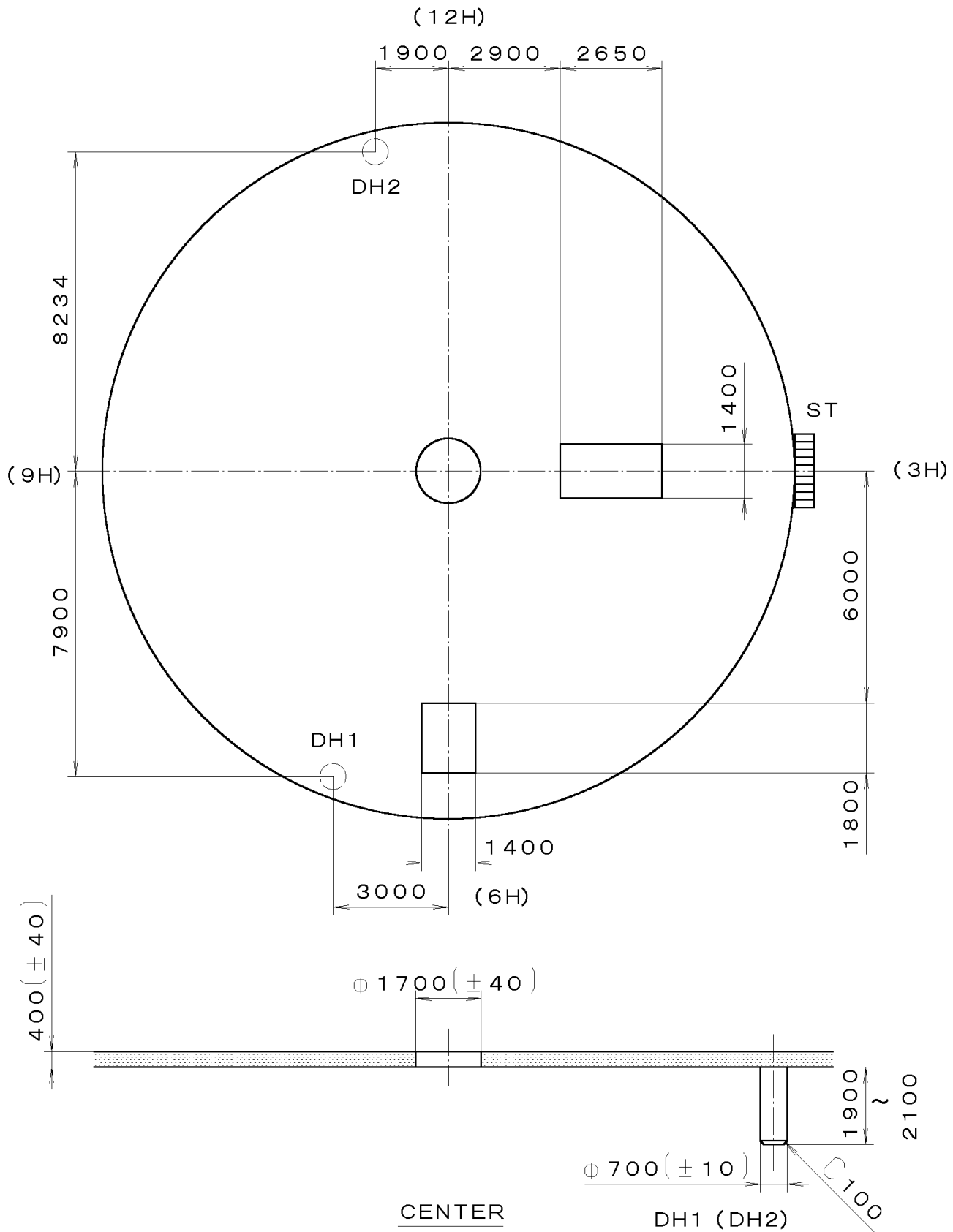

7		Quantity		Cal. No. :	1L02-1AZ
6		Unit	1/1000 mm	Parts:	
5		Scale	7:1	Name:	Indications for Dial
4		Date		Drawing No. :	1L02D040
3		Drawn			
2		Checked	T. Hiruta		
1		Approved			
Material					
Heat Treatment		General Tolerances		CITIZEN WATCH CO., LTD. TOKYO, JAPAN	
Hardness		Dimensions			
Plating		Angles			

This drawing is provisional and subject to our reconfirmation and/or revision without notice.

065-505 (01) *** (2100 1121 A-01 A-01) 00-06-22

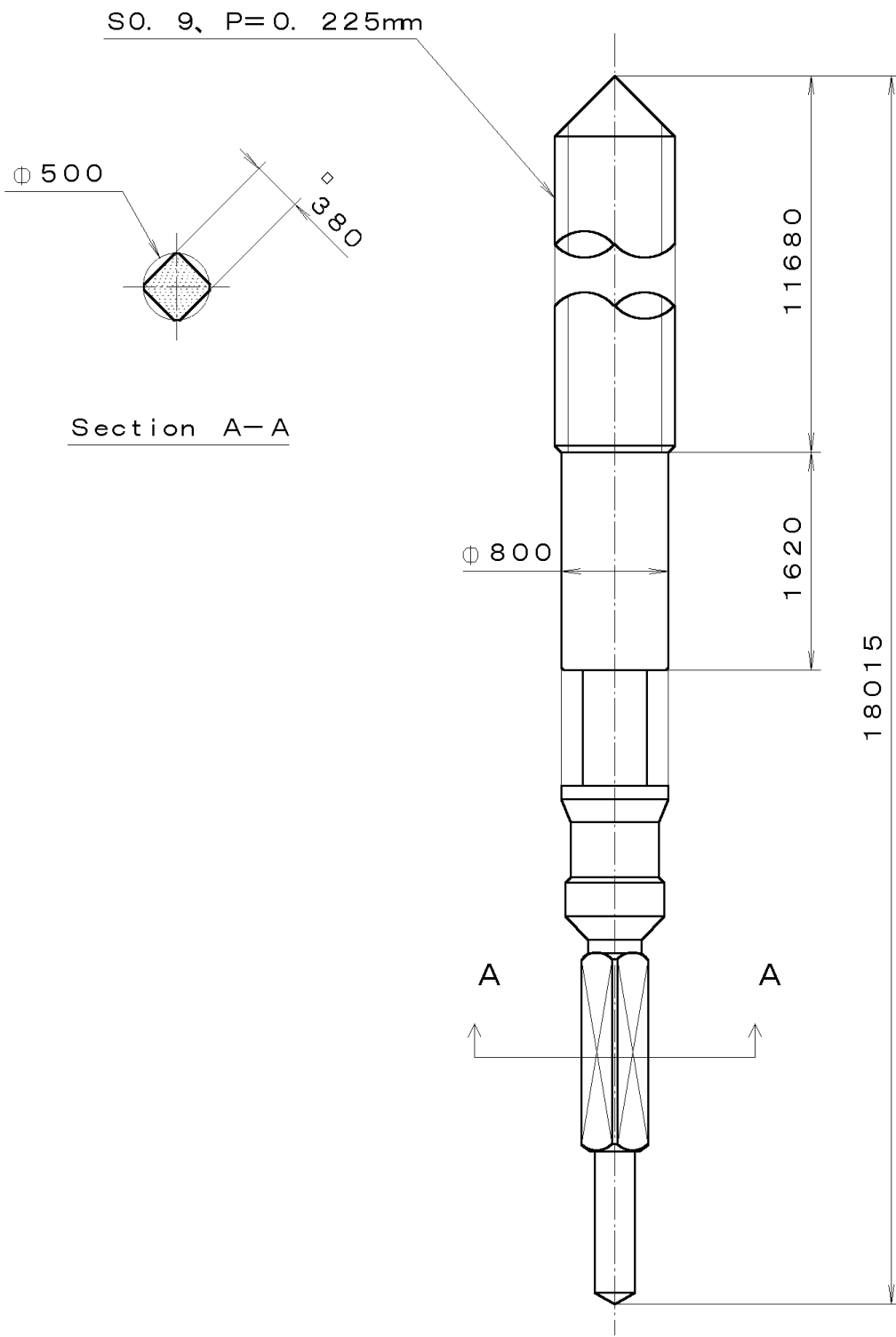

7			Quantity		Cal. No. :
6			Unit	1/1000 mm	
5			Scale	20:1	Parts:
4			Date		065-505
3			Drawn		Name:
2			Checked	T. Hiruta	SETTING STEM
1			Approved		Drawing No. : 5050S000
Material			General Tolerances		CITIZEN WATCH CO., LTD. TOKYO, JAPAN
Heat Treatment			Dimensions		
Hardness			Angles		
Plating					